

RAM Technologies

PFC310PCX 310 WATT MEDICAL GRADE POWER SUPPLY



The PFC310PCX is the latest generation ATX power supply. The high efficiency design is an affordable solution for powering the most critical medical applications. Standard features include low noise dual Smart Fan Technology and optional interface to our patented Ultra capacitor UPS modules.

MADE IN THE USA

Specifications

Input

Input Voltage Range: 100 to 250 VAC +/-10%
Supply overvoltage: Cat Two <300V
Input current: 4.75A A MAX
Frequency: 50/60 HZ
Inrush Current: 35A Cold @ 264 VAC
Efficiency: 75% to 80% TYP.
PFC Correction: Active > .95
Leakage Current: < 250uA @ 264 VAC 60HZ
Input Fuses: 2X 6.3A 250V Line & Neutral

Output

Max output power: 310 Watts continuous
Hold-up Time: >40ms @ full load
Overvoltage Protection: +15% of set voltage
Thermal Protection: Auto Recovery/ cycle pwr. on
Minimum Loading: None
Cross regulation: <0.5%
Line Regulation: <0.05%
Load Regulation: <1% +/- cable factor
AC turn on time: < 2 sec

Output Voltage	+12V	+5V	+3.3V	-12	-5	+5Vsb
Output current max.	25A	30A	28A	1.2A	0.5A	2.0A
Ripple mV P-P	100	50	50	50	50	50

1. Max output from +5V & +3.3V= 180 Watts. When loading the +5 & +3.3V, multiply total load by 1.2 and subtract from 310W.
2. Output derates from 100VAC to 85VAC 3.5W/Volt
3. Total output from all outputs shall not exceed 310Watts
4. Initial voltage +/-3%

Environmental

Operational Temperature: 0 to 50°C
Storage Temperature: -40 to 80°C
Operational Humidity: 0 to 95%NC
Storage Humidity: 0 to 95%NC
Operational Altitude: -500 to 9840 FT
Storage Altitude: -500 to 40,000 FT
Pollution Degree Class: Two

Reliability

MTBF (demonstrated): > 500,000 hours
Expected Life: >8 years when use as specified

EMC Compliance

EN61000-4-2 ESD level3
EN61000-4-3 RF susceptibility 3v/m
EN61000-4-4 EFT level3
EN61000-4-5 Surge Level3
EN61000-3-2 Harmonics
EN61000-3-3 Flicker
EN61000-4-11 Voltage Dips, Short Interruptions
EN55011 Conducted and radiated emissions

STANDARDS Compliance

Desktop Platform Form Factors: REV 1.1 March 07
IEC60601-1 2nd & 3rd edition
RoHS compliant. UL file E191947 ISO9001:2008
Lead free ROHS and REACH compliant

RAM Technologies LLC · 29 Soundview Road Suite 12 · Guilford CT 06437 USA.

Phone: (203) 453 3916 · Fax: (203) 453 3913 · Email: info@ramtechno.com

www.ramtechno.com

PFC310PCX MEDICAL GRADE POWER SUPPLY

Safety Approved to the following standards
 ANSI/AAMI ES 60601-1:2005 ME-Part 1 and CSA C22.2
 No. 60601-1:08(ME-Part 1: General Requirements for
 Basic Safety and Essential Performance)
 IEC 60601-1:2005 (ME Part 1: General Requirements for
 Basic Safety and Essential Performance – Edition 3)

 For Continued protection equipment must be grounded at all times in accordance with the requirements of class 1 devices.

 RAM TECHNOLOGIES LLC declares that the PC and PCX power supplies are in conformity with the provisions of the low voltage directive.

See website [DOWNLOADS](#) for enclosure CAD files

Symbols Used



Attention, consult accompanying documents



Protective earth ground



Caution

Power Good Signal

The Power Good Signal asserts itself high 200ms after all outputs have reached their operational values. Power Good Signal will go low when input stored energy can no longer support the outputs.

Intended Use: The PFC310PCX is intended to power imbedded ATX style motherboards in mission critical medical applications.

Mechanical Specifications

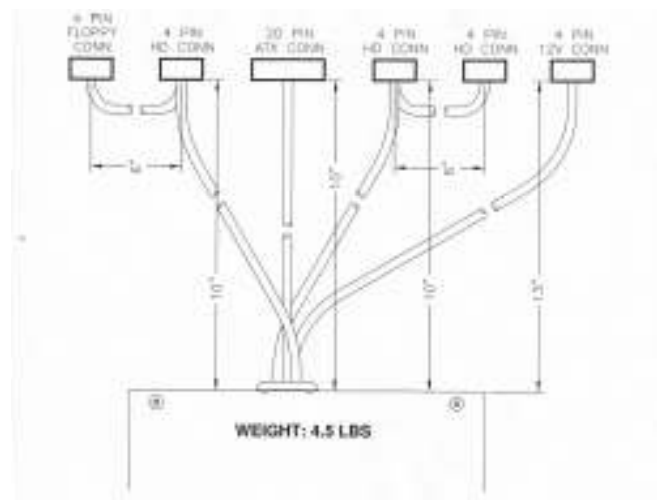
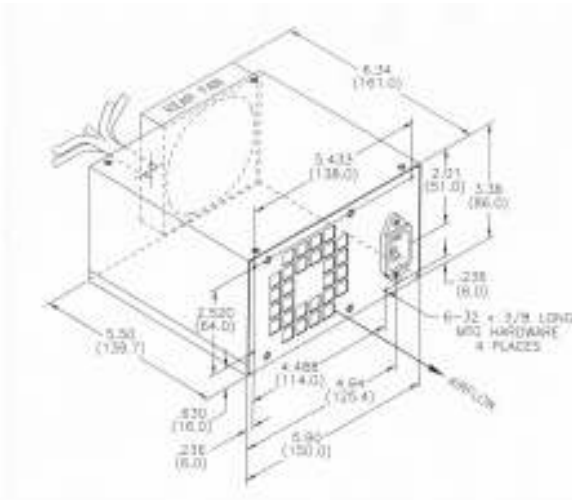

WE OFFER A WIDE VARIETY OF OUTPUT CABLES PLEASE CONTACT FACTORY FOR DETAILS

RAM P/N
 #620012
 Order #
 0012

GND) Black	1 3	White (+12V)
GND) Black	2 4	White (+12V)
GND) Black	3 7	White (+12V)
GND) Black	4 8	White (+12V)

(GND) Black	1 3	Yellow (+12V)
(GND) Black	2 4	Yellow (+12V)

ATX12V Connector

(+3.3V) Orange	1 11	Orange (+3.3V)
(+3.3V) Orange	2 12	Blue (-12V)
(GND) Black	3 13	Black (GND)
(+5V) Red	4 14	Green (PS-ON)
(GND) Black	5 15	Black (GND)
(+5V) Red	6 16	Black (GND)
(GND) Black	7 17	Black (GND)
(PG) Gray	8 18	White (-5V)
(+5VSB) Violet	9 19	Red (+5V)
(+12V) Yellow	10 20	Red (+5V)

20 Pin ATX Connector

RAM P/N
 #620002
 +
 #620031

(+3.3V) Orange	1 13	Orange (+3.3V)
(+3.3V) Orange	2 14	Blue (-12V)
(GND) Black	3 15	Black (GND)
(+5V) Red	4 16	Green (PS-ON)
(GND) Black	5 17	Black (GND)
(+5V) Red	6 18	Black (GND)
(GND) Black	7 19	Black (GND)
(PG) Gray	8 20	White (-5V)
(+5VSB) Violet	9 21	Red (+5V)
(+12V) Yellow	10 22	Red (+5V)
(+12V) Yellow	11 23	Red (+5V)
(+3.3V) Orange	12 24	Black (GND)

24 PIN Optional
 PCI-X Connector

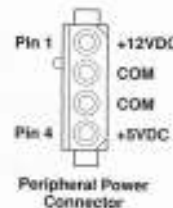

Example:
 PFC400PCX-0016

RAM Technologies LLC • 29 Soundview Road Suite 12 • Guilford CT 06437 USA.
 Phone: (203) 453 3916 • Fax: (203) 453 3913 • Email: info@ramtechno.com

www.ramtechno.com