Application Note AN-11
Revised March 2011

ELECTRICAL SAFETY IN PC BASED MEDICAL PRODUCTS, INCLUDING CHANGES IN IEC 601-1 3RD EDITION

Options and Solutions

By Richard A. Mentelos, RAM Technologies, LLC

RAM Technologies

RAM Technologies, LLC • 29 Soundview Road • Guilford, CT 06437
Phone: (203) 453-3916 • FAX: (203) 453-3913
E-Mail: info@ramtechno.com • www.ramtechno.com

INTRODUCTION

Personal Computers (PCs) are ideal platforms for certain medical products. The vast array of software and peripherals can significantly lower development costs and decrease time to market.

System designers can focus on the operating system and user interface while specialty hardware can be developed such as physiological or transducer interfaces. The interface boards can be inserted into ISA or PCI slots. This application note deals with making a common PC electrically safe for patient connected products. According to Standards IEC601-1 or UL2601-1, any electrical device that is in the vicinity of six feet beyond the perimeter of the bed, examination table, dental chair and the like must conform to the leakage current requirements of IEC601-1 or UL2601-1.

The generic power supply (AT or ATX) that is generally used is approved to Standards IEC950 or UL1950. These power supplies are unsafe for use in a medical environment because of high leakage current and type of insulation. To insure compliance with applicable standards, measures must be taken to upgrade the primary power supply to conform to the standards.

ELECTRICAL SAFETY

In addition to the applicable standards, the power supply and patient connected parts must conform to the leakage current requirements shown in Table 1.

Table 1. Leakage Current Limits (mA) for Type BF and CF Applications

Leakage Location	Test Condition	UL2601-1	IEC601-1 2 nd	IEC601-1 3 rd
Earth Leakage:	NC	0.3	0.5	5
	SFC	0.3	1.0	10
Enclosure/ Touch Leakage:	NC	0.3	0.1	0.1
	SFC	0.3	0.5	0.5
Patient Applied Part Leakage:				
	BF	NC SFC	0.1 0.5	0.1 0.5
CF	NC	0.01	0.01	0.01
	SFC	0.05	0.05	0.05

In 2005 the 3rd edition of IEC601-1 was approved by Association for the Advancement of Medical Instrumentation (AAMI) and the International Electrotechnical Commission (IEC). When Underwriters Laboratories (UL) adopted the 2nd edition of IEC601-1 and added several US deviations, UL labeled the standard UL2601-1. With the adoption of the 3rd edition UL has homogenized their standard with IEC601-1.

There are several differences which are notable between the 2nd and 3rd edition. The most notable changes are the addition of Risk Management Clause 4.2 and conditional increase in Earth Leakage Current.

When applying for approval, one must submit along with the end product, a Risk Management file in accordance with ISO 14971. The 3rd edition is meant only to serve as a “guideline” in the Risk Management process.

It is beyond the scope of this paper to delve into the Risk Management requirement. This paper is meant to enlighten the reader in the area of Electrical Safety as it pertains to PC based medical devices and the basic requirements for leakage current, Hi-POT, and EMC requirements.

The 3rd edition allows 10 times the amount of Earth leakage current than the 2nd edition providing the “Touch Current” limits (formerly known as Enclosure leakage current in the 2nd edition) are met. This applies to devices that are completely housed in non-conducting material and have no access to “earthed” or “live parts”. If the enclosure has an equipotential post or access to any part of the chassis the Touch Current limits apply and must be less than 0.5mA in the single fault condition (S.F.C.).

Regardless of the leakage current the power supply must still be constructed to the requirements of the 3rd edition of IEC601-1.

Since most non-medical grade power supplies will have leakage currents that meet the new standard the non-medical power supply will likely not be constructed with the appropriate clearances and insulation requirements which still apply to medical devices. There is also a new leakage current requirement (Clause 8.7.3e) which does not allow leakage currents greater than 10mA in Normal Condition (N.C.) when measured with a non-frequency weighted device.

The main difference between IEC601-1 and UL2601-1 is the leakage current. For Class 1 devices (devices that require a ground for safety) the leakage current for UL2601-1 at 264 VAC, 60 Hz is 300 μ A and the leakage current for IEC601-1 at 264 VAC, 50 Hz is 500 μ A. The network schematic for the measuring device is shown in Figure 1. The network compensates for frequency vs. current. Most devices are Class I. Class II devices are double insulated and do not require grounding for safety.

Agency testing requires that the power supply be tested 10% higher than the highest rated input voltage. Power supplies operate from 100 VAC to 240 VAC which is a range of 85 to 264 VAC. The electrical system in the United States is different than in Europe and other countries. In the United States a 240 VAC line (208 to 240) is comprised of two “hot” leads and a neutral. The voltage between line and neutral is 120 VAC and the voltage between line and line is 240 VAC. The voltage is therefore “center-tapped” around ground. Outside the United States there is only one “hot” lead and a neutral so the voltage relative to ground is the full line voltage which can be as high as 264 VAC.

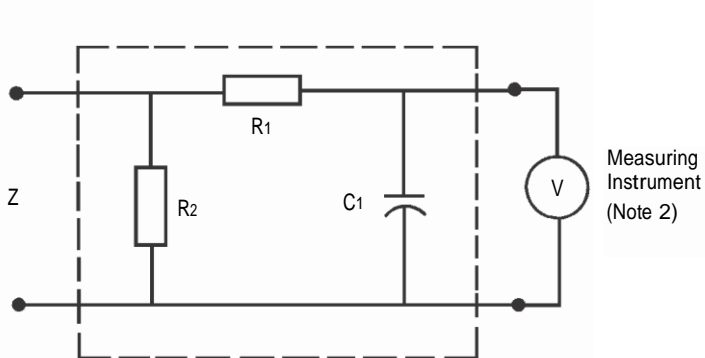
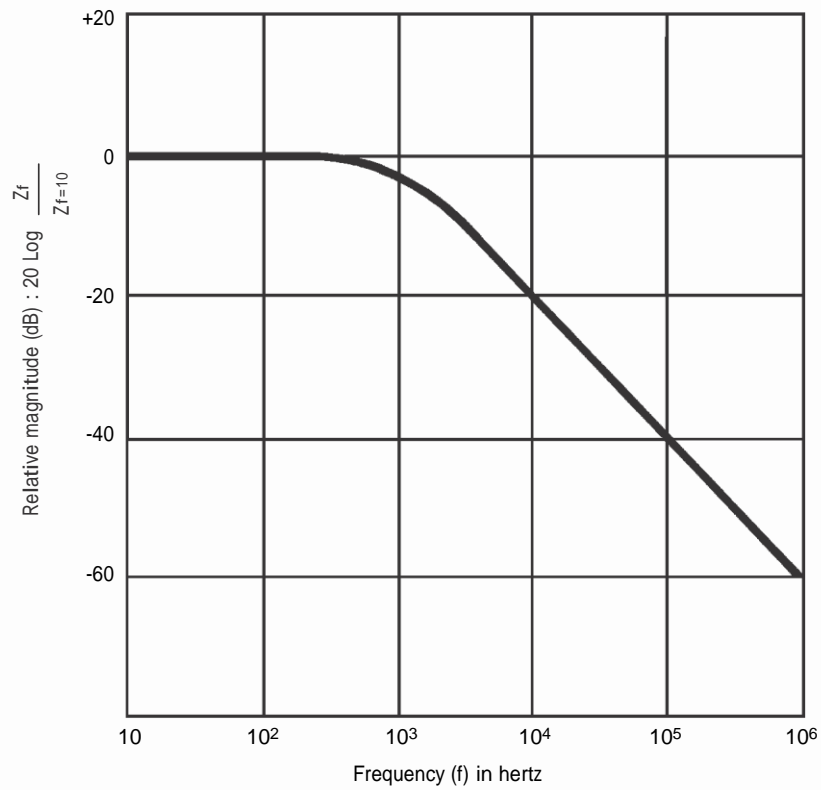

Equivalent to the circuit shown on the left in subsequent figures.

- R1 = 10 k ± 5% (Note 1)
- R2 = 1 k ± 1% (Note 1)
- C1 = 0.015 μF ± 5% (Note 1)

- Notes:
1. Non-inductive components
 2. Impedance > measuring impedance Z

Figure 1. Example of a Measuring Device and Its Frequency Characteristic

LEAKAGE CURRENT

The cause of leakage current is due to two factors. One is the parasitic capacitance of the isolating transformer and surrounding components. The other cause is that of “Y” capacitors (line to ground). The “Y” capacitors suppress EMI from being conducted out into the line. In most cases the “Y” capacitors dominate and are responsible for the bulk of the leakage current.

The enclosure or Touch leakage is measured by inserting the measuring device in series with the ground conductor. For patient connected equipment the neutral line is always closed (S1). The line and neutral are reversed (S2). The maximum leakage current at 132 VAC, 60 Hz is 300 μ A.

IEC/UL2601-1. The two types of leakage current measurements are earth and enclosure. **Earth leakage** is measured by putting the measuring device in series with the ground conductor and opening the neutral

line at 264 VAC. Opening the neutral is considered a single fault condition and represents the worst case condition. The current limit for this measurement is 1 mA. In the 3rd addition 10mA Earth Leakage current is allowed providing the requirements for Touch current are met.

Enclosure/Touch leakage current is measured by inserting the measuring device in series with the grounding post on the enclosure and ground. The single fault condition is obtained by opening the ground wire and measuring the leakage current with the neutral intact. The current limit is 500 μ A. Figure 2 is the diagram for the test setup for measurement of Earth Leakage. Figure 3 is the diagram for Enclosure Leakage current.

United States Deviations. There is one deviation in Specification UL2601-1 for the United States when employing a 264 VAC center-tapped (CT) transformer. When using the CT transformer, the same tests are performed but the enclosure leakage current is 300 μ A maximum.

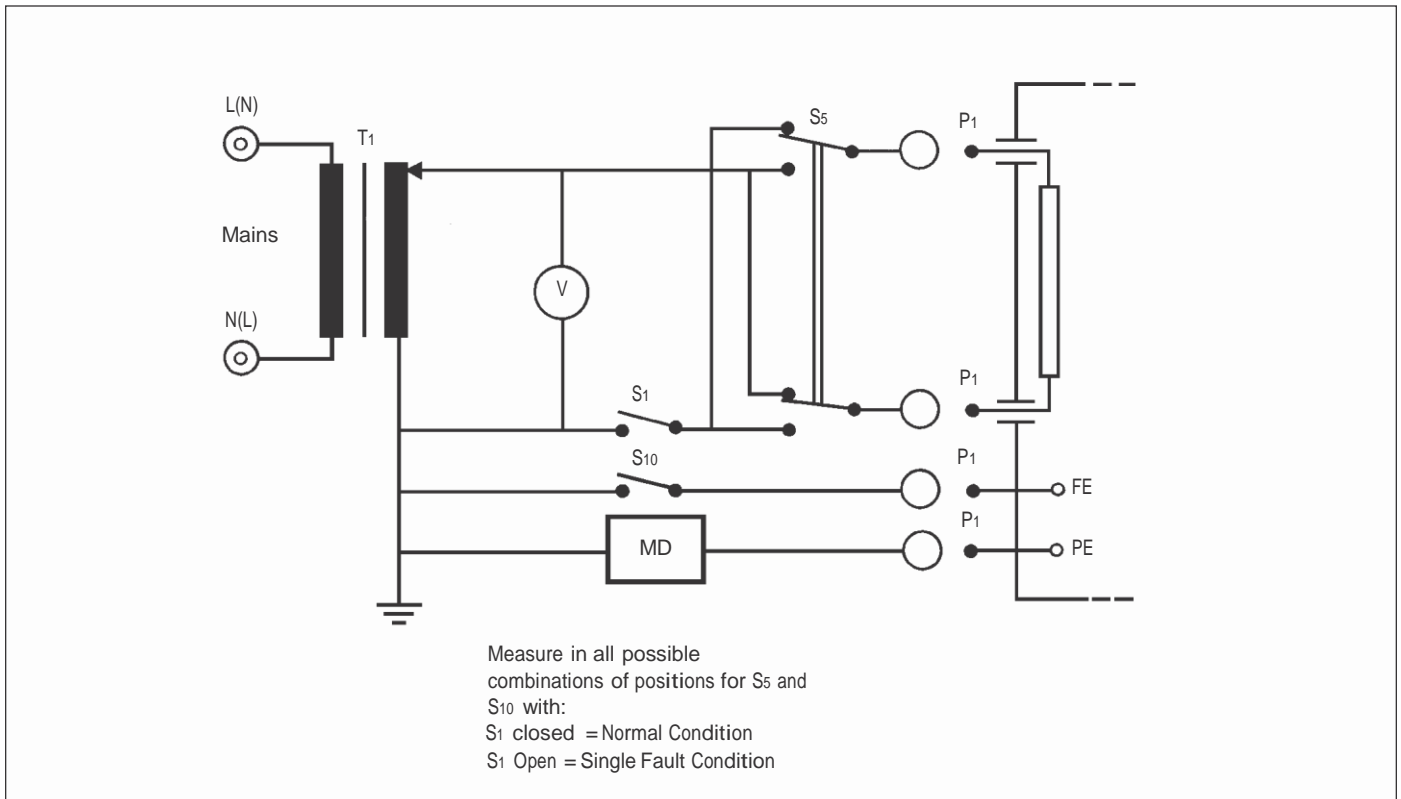

Figure 2. Measuring Circuit for the Earth Leakage Current of Class 1 Equipment, with or without Applied Part.

APPLIED PARTS

Safety agencies define direct electrical contact to the patient as an “applied part”. Examples of this are ECG leads, SPO₂ sensors, ultrasound transducers, etc. Type BF conditions exist when an applied part makes electrical contact with the patient (Body Floating). A CF condition exists when the applied part is connected directly to the Heart (Cardiac Floating).

Applied parts must be isolated by themselves and be capable of withstanding line and defibrillation voltages. It is good practice to isolate applied parts to withstand 4 KV RMS. This requires a creepage distance (distance along a surface) of 8 mm and clearance (distance through air) of 5 mm. The single fault leakage current for an applied part is 50 µA at 264 V RMS.

HI-POT REQUIREMENTS

The standards require that the unit withstand various Hi-Pot potentials depending on the maximum line voltage and application.

Power supplies have two types of insulation, basic and double. The Hi-Pot requirement for primary-to-ground basic insulation is 1500 V RMS (for 1 min.) and for double insulation it is 4,000 V RMS (for 1 min.). DC Hi-Pot may be used if you multiply the AC RMS value by 1.414.

When power supplies are tested by various agencies, they test the input to output at 4,000 V RMS. Most power supplies have the secondary ground referenced. This means the primary to ground could be 4,000 V RMS, which can overstress basic insulation. In most power supplies the input line filters are only designed to withstand 1,500 V RMS, so the agencies will allow the input filter to be removed for Hi-Pot testing. Once the power supply is installed in the PC, the Hi-Pot potentials should only be applied from primary to chassis (1500 VAC or 2121 VDC).

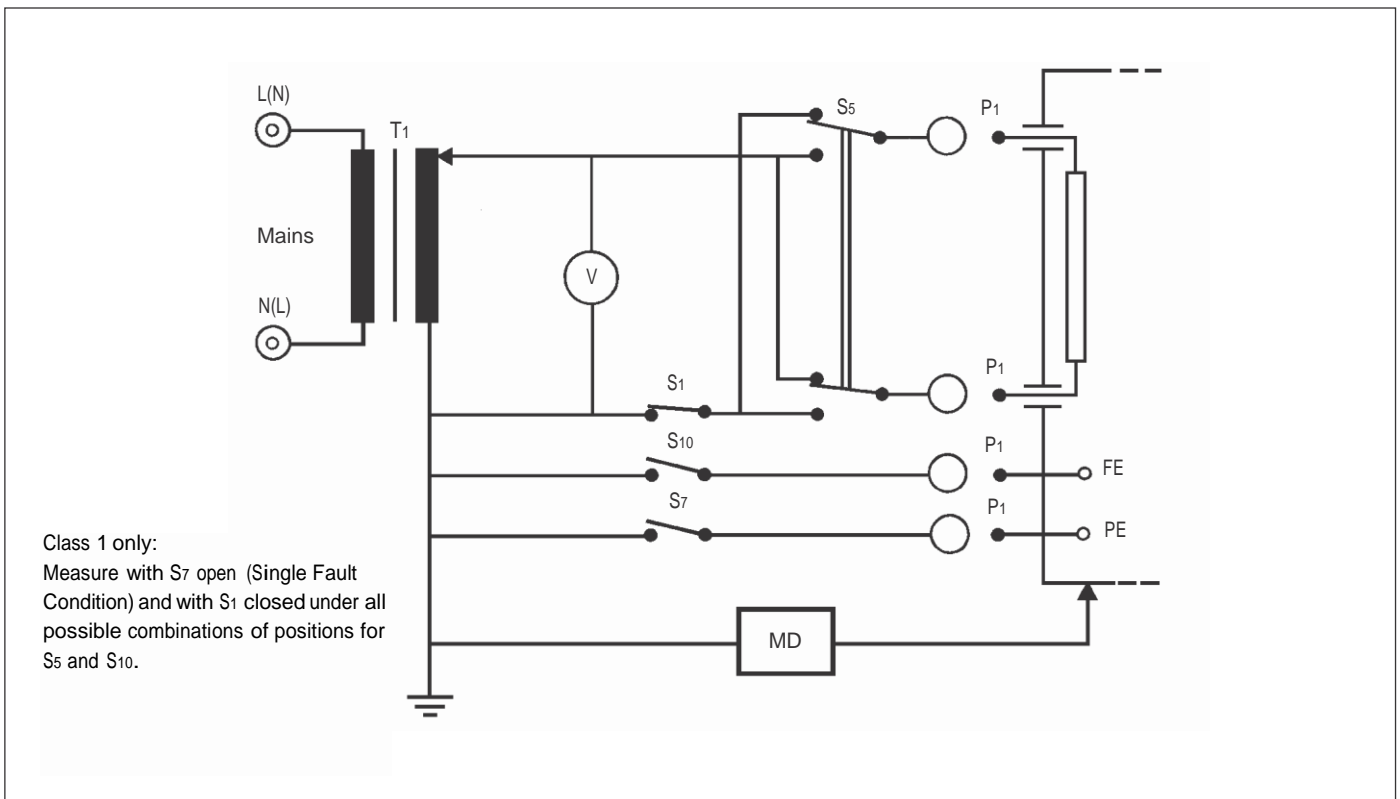

Figure 3. Measuring Circuit for Enclosure Leakage Current.
(For Class II Equipment the protective earth connection and S7 are not used.)

METHODS OF COMPLIANCE

To reduce leakage current to a safe value, there are two options. One option is an isolation transformer and the other is a medical grade PC power supply.

Isolation transformers are typically toroidal to minimize size, weight and radiated 50/60 Hz magnetic fields. They are usually housed in a metal box with several hospital grade outlets. The leakage current of most toroids is around 50 μ A. Depending on their VA rating, they can be quite bulky and hard to mount. Also they subtract from overall system efficiency and do nothing for power factor correction.

Medical grade PC Power Supplies are the best solution for reducing chassis leakage current and they conform to safety standards. Because they are mounted directly inside the computer chassis, there are no bulky external units to deal with. The internal structure of the supply has been built to maximize patient safety under a variety of conditions such as high temperature and humidity.

The medical PC power supply can offer advantages that external isolation transformers can't. For example universal input (85 to 264 VAC continuous without a switch), power factor correction, and improved efficiency.

POWER FACTOR CORRECTION

On January 1, 2001, two new standards went into effect for Europe: EN61000-3-2 (power line harmonics) and EN 61000-3-3 (power line flicker). All products shipped into Europe or placed on the market in Europe as of January 1 must have been tested and found compliant to these standards. Power supplies will require the addition of PFC (power factor correction) to comply with the harmonics standard. Products not complying to these standards on January 1, 2001 will not be allowed to pass through European customs if an audit is conducted.

All switching power supplies draw current from the line in narrow, high-amplitude pulses instead of a smooth sinusoidal flow from the AC mains. Since power factor is the ratio of real power (P_R) to apparent power (P_A):

$$\begin{aligned} PF &= \frac{P_R}{P_A} \\ &= \frac{P_{input}}{V_{RMS} \times I_{RMS}} \end{aligned}$$

The power factor of a typical switching supply is 0.6 to 0.7, whereas a power factor corrected power supply is typically 0.95 or greater. The high current pulses can distort the main voltage waveform and possibly cause interference with other equipment sharing the line. Power factor corrected supplies will allow the hospital to run more equipment off the same line because the peak current is far less for the same power. This is becoming increasingly more important as more electronic devices are being operated from the hospital power mains. Isolation transformers do nothing for the power factor and, in fact, increase the amplitude of the current pulses drawn from the line due to their inefficiency.

OTHER DESIGN CONSIDERATIONS

Output Regulation. Other considerations for the power supply should include power output and regulation. Some medical PC power supplies require that the +5 or +3.3 VDC outputs have minimum loading which can cause increased cross regulation problems with the other outputs. Since it is likely that PC based medical products will have custom peripheral devices that can draw large amounts of current, it is important that the power supply be capable of maintaining its regulation over a wide range of loads.

Emissions and Susceptibility. A properly designed medical PC power supply, will be able to comply with IEC601-1-2, which requires compliance to the following standards:

- EN61000-4-2 ESD Level 3
- EN61000-4-3 RF Susceptibility 3 V/M
- EN61000-4-4 EFT Level 3
- EN61000-4-5 Surge Level 3
- EN61000-3-2 Harmonics
- EN61000-4-6 Conducted RF
- EN61000-4-11 Voltage Dips & Interrupts
- EN61000-3-3 Power Line Flicker
- EN55011 Class A or B

Class A devices are all medical devices used in a hospital or other health care facility and Class B devices are intended to be used in the home. Class A devices may be used in the home if they are operated by a qualified person.

Using an isolation transformer instead of a medical power supply may make meeting these requirements very difficult. Most EMC test facilities can test your product for compliance to IEC601-1-2. With a medical grade PC power supply, compliance is almost guaranteed.

UPS OPERATION

In critical applications where loss of function could be considered a hazard employing an uninterruptible power supply (UPS) can be an elegant solution. With the requirement of IEC 61000-4-11 Voltage Dips and Interruptions compliance can only be truly met with the aid of a UPS.

Up until now the only medical grade UPS was a large stand alone external device that will provide power during an outage. External UPS's store their energy in lead acid batteries and usually require 6 to 12 hours for recharge. Like most stand by devices, regular maintenance is required to ensure reliable operation.

Recently RAM Technologies has introduced a UPS option for their line of medical grade power supplies that works on Ultra Capacitors rather than batteries thus eliminating the requirement for maintenance.

The Ultra Capacitor module is physically located inside the PC enclosure eliminating bulky external devices. The Ultra Capacitor module can be expanded to increase the back up operation time.

INVERTER OPERATION

Some applications require operation from a DC source. It is common practice to use an inverter to convert DC to AC. Most inverters produce a square wave output or modified sine wave output.

Because of the capacitor input of most switching power supplies, the input current pulses can be quite high resulting in loss of energy due to low power factor.

Power factor corrected power supplies allow much more efficient operation from inverters because the peak currents are about one quarter that of capacitor input supplies. Using a power factor corrected supply can result in an improvement in overall efficiency of up to 15 percent.

A word of warning about 230V modified sine wave inverters/UPS's. Most power factor corrected ATX power supplies will not tolerate the high peak voltage from 230V inverter/UPS's and it is recommended to use a true sine wave output for 230V operation.

CONCLUSION

Using a Medical Grade power supply specifically designed for operation in a Personal Computer will save the system designer time and money by insuring that the system meets all the applicable safety and emission standards. Often the power supply is the last item in a system that is to be evaluated. The designer is encouraged to contact the manufacturer in the beginning phases of the system design so that issues such as custom cable lengths or custom features can be realized and accepted by approval agencies.

Series PFC Power Supplies, manufactured by RAM Technologies, incorporates all the safety features described in this application note. All RAM Technology Medical Power Supplies are fully compliant to the latest UL and IEC Specifications.



Figure 4. Typical Series PFC Medical Power Supply.

**Application engineers are
available to discuss particular
applications and make appropriate
design suggestions as required.**

RAM Technologies

RAM Technologies, LLC • 29 Soundview Road • Guilford, CT 06437
Phone: (203) 453-3916 • FAX: (203) 453-3913
E-Mail: info@ramtechno.com www.ramtechno.com